

PSF™ 250
PSF™ 305
PSF™ 405
PSF™ 505
PSF™ 405 RS3



PSF™ 410w
PSF™ 510w
PSF™ 410w RS3
PSF™ 510w RS3

PSF™ 250C
PSF™ 315C LD
PSF™ 405C
PSF™ 405C RS3



PSF™ 410Cw
PSF™ 410Cw RS3

PSF™ 315M/315R

MXH™ 300 PP
MXH™ 400wPP



Spare Part Catalogue

ORDERING NUMBERS	3
PSF 250	8
PSF 305, 405, 505, 405 RS3	10
PSF 410w, 410w RS3, 510w, 510w RS3	12
PSF 315M/R	14
PSF 250C, PSF 315CLD	16
PSF 4 05C, PSF 405C RS3	18
PSF 410CW, PSF 410CW RS3	20
MXH 300 PP	22
MXH 400w PP	24
WEAR COMPONENTS	26
ACCESSORIES	33
Notes	34

Welding guns & torches

Spare parts are to be ordered through the nearest ESAB agency. Kindly indicate type of unit, serial number, denominations and ordering numbers according to the spare parts list.

Maintenance and repair work should be performed by an experienced person, and electrical work only by a trained electrician. Use only recommended spare parts.



Ordering number *PSF™ 250, 305, 405, 505, 405 RS3*

Order Nos	Type	Description
0368 100 882	PSF™ 250	Welding Torch 3.0 m
0368 100 883	PSF™ 250	Welding Torch 4.5 m
0458 401 880	PSF™ 305	Welding Torch 3.0 m
0458 401 881	PSF™ 305	Welding Torch 4.5 m
0458 401 882	PSF™ 405	Welding Torch 3.0 m
0458 401 883	PSF™ 405	Welding Torch 4.5 m
0458 401 884	PSF™ 505	Welding Torch 3.0 m
0458 401 885	PSF™ 505	Welding Torch 4.5 m
0458 401 892	PSF™ 405 RS3	Welding Torch 3.0 m
0458 401 893	PSF™ 405 RS3	Welding Torch 4.5 m
0459 694 990	Spare Parts Catalogue	

Ordering number *PSF 410w, 410w RS3, 510w, 510w RS3*

Order Nos	Type	Description
0458 400 882	PSF™ 410w	Welding Torch 3.0 m
0458 400 883	PSF™ 410w	Welding Torch 4.5 m
0458 400 886	PSF™ 410w	Welding Torch 5.0 m
0458 400 884	PSF™ 510w	Welding Torch 3.0 m
0458 400 885	PSF™ 510w	Welding Torch 4.5 m
0458 400 887	PSF™ 510w	Welding Torch 5.0 m
0458 400 898	PSF™ 410w RS3	Welding Torch 3.0 m
0458 400 899	PSF 410w RS3	Welding Torch 4.5 m
0458 400 900	PSF 510w RS3	Welding Torch 3.0 m
0458 400 901	PSF 510w RS3	Welding Torch 4.5 m
0459 694 990	Spare Parts Catalogue	

Welding guns & torches



Ordering numbers for PSF™ 315 M, PSF™ 315 R

0367 233 894	PSF™ 315 M / 315 R, 25°	Welding Torch 1.5 m
0367 233 896	PSF™ 315 M / 315 R, straight	Welding Torch 1.5 m
0367 233 898	PSF™ 315 M / 315 R, 25°	Welding Torch 3.0 m
0367 233 900	PSF™ 315 M / 315 R, 25°	Welding Torch 2.2 m
0367 233 901	PSF™ 315 M / 315 R, straight	Welding Torch 2.2 m
0367 233 904	PSF™ 315 M / 315 R, 25° extended	Welding Torch 1.5 m
0367 233 905	PSF™ 315 M / 315 R, straight	Welding Torch 3.0 m
0459 694 990	Spare Parts Catalogue	

Ordering numbers for other lengths

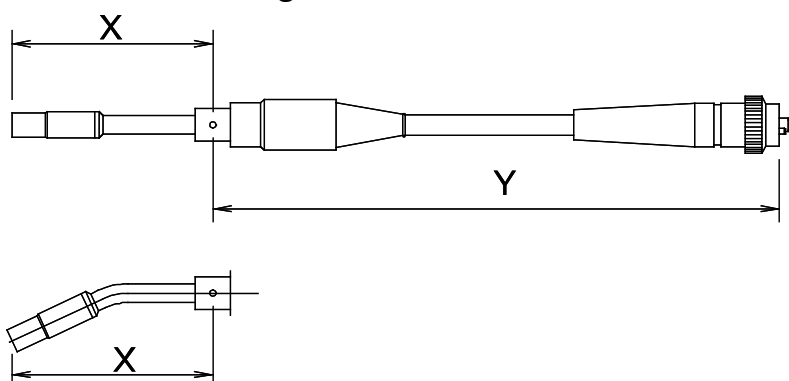

When ordering please quote:

- Neck type
- Wire diameter
- Cable assembly length

These ordering numbers apply only to standard torch variations. Other variations will be issued with part numbers on receipt of order. Refer to order confirmation.

Order form for torch with extended swan neck or custom specific length 0367 233 90x						
PSF™ 315M / R	Item no 0367 233 xxx	1.5 m	2.2 m	3.0 m	Free length*	X (mm)
Swan neck 25°	(0368 155 890)	894	900	898		196.3
Swan neck straight	(0368 155 894)	896	901	905		209.3
Swan neck 25° ext. 100	(0368 155 892)					296.3
Swan neck straight, ext. 100	(0368 155 896)					309.3
Length Y (± 20 mm)		1300 mm	2040 mm	3000 mm		

* Specify length Y = in the correct column (swan neck)

Welding guns & torches



Ordering number *PSF™ 250C, PSF™ 315CLD, PSF™ 405C, PSF™ 410Cw, PSF™ 410Cw RS3*

Order Nos	Type	Description
0468 410 882	PSF™ 250C	Welding torch 3.0 m
0468 410 883	PSF™ 250C	Welding torch 4.5 m
0468 410 885	PSF™ 315CLD	Welding torch 3.0 m
0468 410 886	PSF™ 315CLD	Welding torch 4.5 m
0458 499 882	PSF™ 405C	Welding torch 3.0 m
0458 499 883	PSF™ 405C	Welding torch 4.5 m
0458 450 880	PSF™ 410Cw	Welding torch 3.0 m
0458 450 881	PSF™ 410Cw	Welding torch 4.5 m
0458 450 884	PSF™ 410Cw RS3	Welding torch 3.0 m
0458 450 885	PSF™ 410Cw RS3	Welding torch 4.5 m
0459 694 990	Spare Parts Catalogue	

Welding guns & torches

Ordering number **MXH™ 300 PP / MXH™ 400w PP**



Order Nos	Type	Description
0700 200 015	MXH™ 400w PP	Welding gun 6 m
0700 200 016	MXH™ 400w PP	Welding gun 10 m
0700 200 017	MXH™ 300 PP	Welding gun 6 m
0700 200 018	MXH™ 300 PP	Welding gun 10 m
0700 200 019	MXH™ 400w PP 45°	Welding gun 10 m
0459 694 990	Spare Parts Catalogue	

The spare parts list is available on the Internet at **www.esab.com**
Under "Products" and "Welding & cutting equipment", you will find a link to the page where you can both search for and download instruction manuals and spare parts lists.

(x) = standard delivery (W) = wear part (A) = accessory

Pos	Denomination	Ordering no.	PSF 250	Notes
	Welding torch 3.0 m	0366 100 882		EURO Connection
	Welding torch 4.5 m	0366 100 883		EURO Connection
100	Swan neck Complete std 45°	0366 315 880	x	Includes 101, 103, 105, 106
	Swan neck 45°	0459 679 880	(A)	Excludes wear parts and fits PSF 160/250.
100a	Swan neck Complete straight	0469 329 880	(A)	Includes 101, 103, 105, 106
100b	Swan neck Complete 60°	0467 985 880	(A)	Includes 101, 103, 105, 106
101	Gas nozzle standard Ø14	0458 464 881	x	
-	Gas nozzle conical Ø12	0458 465 881	(A)(W)	
-	Gas nozzle straight Ø16	0458 470 881	(A)(W)	
101a	Gas nozzle "Slip-on"	0469 752 880	(A)(W)	
101d	Cooling sleeve "Slip-on"	0469 756 880	(A)	
102	Spatter protection	0458 471 002	x	
102a	Spatter protection "Slip-on"	0469 538 001	(A)(W)	
103	Contact tip			See Wear parts on page 26
104	Tip adapter standard M6	0366 314 001	x	
-	Tip adapter Helix M7	0368 310 001	(A)(W)	
105	Insulation bushing	0366 397 001	x (W)	
106	Protective hose, L=75 mm	0192 086 006	x	Order by length (metre)
107	Plastic nut	0468 886 880	x	
108	Cable support	0468 087 001	x	
109	Trigger kit	0455 407 880	x	
110	Handle complete	0468 912 880	x	Screws included
111	Mechanical switch	0369 611 880	x	
112	Trigger spring	0365 840 880	x	
113	Support sleeve	0700 200 150	x	Complete kit incl screws
114	Adapter nut	0700 200 097	x	
115	Central connector	0700 200 151	x	Incl. control leads

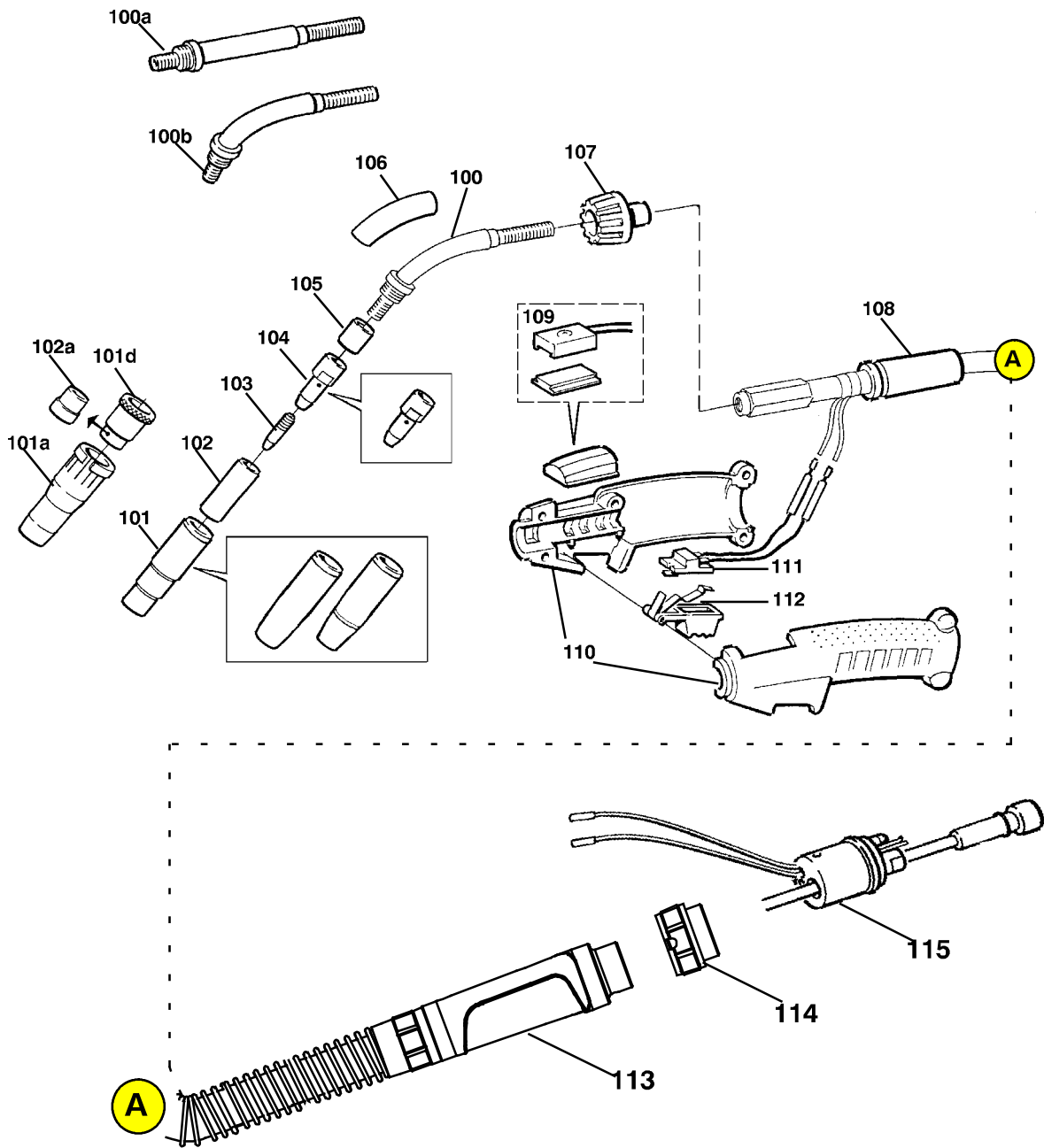

PSF 305, PSF 405, PSF 505

(x) = standard delivery (W) = wear part (A) = accessory

Pos	Denomination	Ordering no.	PSF 305	PSF 405	PSF 505	PSF 405 RS3	Notes
	Welding torch 3.0 m	0458 401	-880	-882	-884	-892	EURO Connection
	Welding torch 4.5 m	0458 401	-881	-883	-885	-893	EURO Connection
200	Swan neck Complete std	0366 388 880	x				Include 201a, 204a
200	Swan neck Complete std	0366 389 880		x		x	Include 201a, 204b
200	Swan neck Complete std	0366 390 880			x		Include 201a, 204b
	Swan neck Complete 60°	0467 988 881	(A)				Include 201a, 204a
	Swan neck Complete 60°	0467 988 880		(A)		(A)	Include 201a, 204b
	Swan neck Complete 60°	0467 989 880			(A)		Include 201a, 204b
	Swan neck Complete straight	0469 333 880	(A)				Include 201a, 204a
	Swan neck Complete straight	0469 334 880		(A)		(A)	Include 201a, 204b
	Swan neck Complete straight	0469 335 880			(A)		Include 201a, 204b
201	Gas nozzle standard Ø16	0458 464 882	x (W)				Include 202
201	Gas nozzle standard Ø17	0458 464 883		x (W)		x (W)	Include 202
201	Gas nozzle standard Ø18	0458 464 884			x (W)		Include 202
201a	Gas nozzle straight Ø19	0458 470 882	(A) (W)				Include 202
201a	Gas nozzle straight Ø21	0458 470 883		(A) (W)		(A) (W)	Include 202
201a	Gas nozzle straight Ø21	0458 470 884			(A) (W)		Include 202
201b	Gas nozzle conical Ø14	0458 465 882	(A) (W)				Include 202
201b	Gas nozzle conical Ø15	0458 465 883		(A) (W)		(A) (W)	Include 202
201b	Gas nozzle conical Ø15	0458 465 884			(A) (W)		Include 202
201c	Gas nozzle "Slip-on"	0469 753 880	(W)				
201c	Gas nozzle "Slip-on"	0469 754 880		(W)		(W)	
201d	Cooling sleeve "Slip-on"	0469 757 880	x (W)				
201d	Cooling sleeve "Slip-on"	0469 758 880		x (W)		(W)	
202	Spatter protection	0458 471 003	x (W)				
202	Spatter protection	0458 471 004		x (W)		x(W)	
202	Spatter protection	0458 471 005			x (W)		
202a	Spatter protection "Slip-on"	0469 539 001	(W)				
202a	Spatter protection "Slip-on"	0469 540 001		(W)		(W)	
203	Contact tip	-					See Wear parts on page 27
204	Tip adapter M6	0366 394 001	x (W)	(W)		(W)	
204	Tip adapter M8	0460 819 001	(W)	x (W)		x (W)	
204	Tip adapter M8	0366 395 001			x (W)		
204	Tip adapter Helix M7	0368 311 001	(A)	(A)		(A)	
	Tip adapter Helix M7	0368 312 001			(A)		
205	Insulation bushing	0366 397 002	x	x		x	PSF 305, 405
205	Insulation bushing	0366 397 003			x		PSF 505
206	Hook	0458 445 001	x	x	x	x	
207	Lock nut with screw	0458 406 881	x	x	x	x	
208	Handle complete	0458 440 881	x	x	x	x	Incl 209, 213, 214, 215
209	Screw 4 pcs (12 mm)	-	x	x	x	x	included in 208
210	Trigger complete	0458 810 880	x	x	x	x	incl.spring
211	Mechanical switch	0369 611 880	x	x	x	x	
212	Remote switch, complete	0458 420 880				x	Included in RS3 models only
213	Blind cover	-	x	x	x		Included in 208
214	Pin	-	x	x	x	x	Included in 208
215	Squeeze ring	-	x	x	x	x	Included in 208
215a	Cable support	0459 692 880	x	x	x	x	Incl svivel ring, rubber sleeve
216a	Support sleeve	0700 200 150	x	x	x	x	Compl. kit incl. screw
216b	Support sleeve	0700 200 152	x	x	x	x	Compl. kit incl. screw

PSF 410w, PSF 510w

(x) = standard delivery (W) = wear part (A) = accessory

Pos	Denomination	Ordering no.	PSF 410w	PSF 510w	PSF 410w RS3	PSF 510w RS3	Notes
	Welding torch 3.0 m	0458 400	-882	-884	-898	-900	EURO Connection
	Welding torch 4.5 m	0458 400	-883	-885	-899	-901	EURO Connection
	Welding torch 5.0 m	0458 400	-886	-887			EURO Connection
300	Swan neck Complete std	0458 403 881	x		x		Include 301a, 304a, 305
300	Swan neck Complete std	0458 403 882		x		x	Include 301a, 304a, 305
300	Swan neck Complete 60°	0458 403 884	(A)		(A)		Include 301a, 304a, 305
300	Swan neck Complete 60°	0458 403 885		(A)		(A)	Include 301a, 304a, 305
300	Swan neck Complete straight	0458 403 886	(A)		(x)		Include 301a, 304a, 305
300	Swan neck Complete straight	0458 403 887		(A)		(A)	Include 301a, 304a, 305
301	Gas nozzle "Slip-on"	0469 753 880	x		x		Include 302a
301	Gas nozzle "Slip-on"	0469 754 880		x		x	Include 302a
301a	Gas nozzle standard Ø16	0458 464 882	x		x		Include 302
301a	Gas nozzle standard Ø17	0458 464 883		x		x	Include 302
301b	Gas nozzle straight Ø19	0458 470 882	(A W)		(A W)		Include 302
301b	Gas nozzle straight Ø21	0458 470 883		(A W)		(A W)	Include 302
301c	Gas nozzle conical Ø14	0458 465 882	(A W)		(A W)		Include 302
301c	Gas nozzle conical Ø15	0458 465 883		(A W)		(A W)	Include 302
301d	Cooling sleeve "Slip-on"	0469 757 880	(W)		(W)		
301d	Cooling sleeve "Slip-on"	0469 758 880		(W)		(W)	
302	Spatter protection	0458 471 003	x (W)		x (W)		
302	Spatter protection	0458 471 004		x (W)		x (W)	
302a	Spatter protection "Slip-on"	0469 539 001	(W)		(W)		
302a	Spatter protection "Slip-on"	0469 540 001		(W)		(W)	
303	Contact tip		(W)	(W)	(W)	(W)	See Wear parts on page 27
304a	Tip adapter M8	0460 819 001	x (W)	x (W)	x (W)	x (W)	
304b	Tip adapter Helix M7	0368 311 001	(W)	(W)	(W)	(W)	
305	Insulation washer	0458 874 001	x (W)	x (W)	x (W)	x (W)	
306	Hook	0458 445 001	x	x	x	x	
307	Current connection	0458 417 880	x	x	x	x	
308	Trigger complete	0458 810 880	x	x	x	x	Including spring
309	Mechanical switch	0369 611 880	x	x	x	x	
310	Screw 4 pcs (12 mm)	-	x	x	x	x	Included in 311
311	Handle spare	0458 440 881	x	x	x	x	Incl 310, 313 and 313
312	Remote switch, complete	0458 420 880			x	x	Included in RS3 models only
313	Blind cover	-	x	x			Included in 311
314	Pin	-	x	x	x	x	Included in 311
315	Support kit	0459 691 880	x	x	x	x	Incl. squeeze ring, swivel, spring
316	Central connector	0700 200 153	x	x	x	x	Including control leads
317	Adapter nut	0700 200 097	x	x	x	x	
318	Current/water cable	0700 200 154	x	x	x	x	3.0 m
318	Current/water cable	0700 200 155	x	x	x	x	4.5 m
318	Current/water cable	0700 200 156	x	x	x	x	5.0 m
319	Support hose 3.0 m	0700 200 157	x	x	x	x	3.0 m
319	Support hose 4.5 m	0700 200 158	x	x	x	x	4.5 m
319	Support hose 5.0 m	0700 200 159	x	x	x	x	5.0 m
320	Support sleeve	0700 200 152	x	x	x	x	Compl. kit incl. screw

PSF 410w, PSF 510w

Pos	Denomination	Ordering no.	PSF 410w	PSF 510w	PSF 410w RS3	PSF 510w RS3	Notes
321	Moss cap	0460 306 880	x	x	x	x	Complete set, 5 blue and 5 red
322	Hose return, red	0456 496 001	x	x	x	x	Order length in metre
323	Hose supply, blue	0456 496 002	x	x	x	x	Order length in metre
324	Hose connection kit	0459 673 880	x	x	x	x	10 pcs Quick connector/clamp
325	Pin plug, 23-pole	0368 541 005			x	x	Included in RS3 models only
326	Contact pin	0323 945 004			x	x	Min. 50 pcs
327	Outer hose	0467 822 004	x	x	x	x	

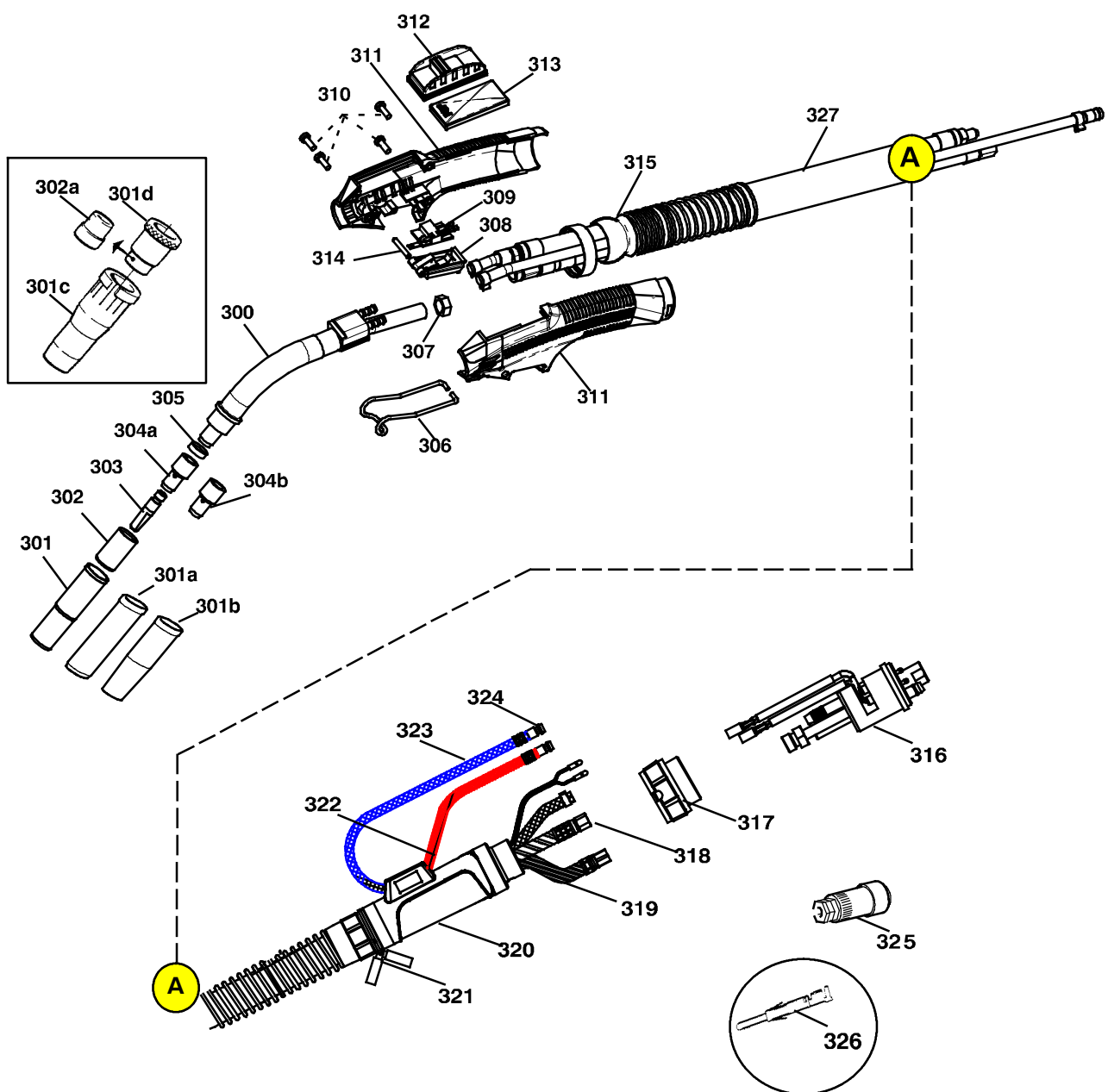

(x) = standard delivery (W) = wear part (A) = accessory

Pos.	Denomination	Ordering no.	PSF 315R / 315M	Notes
400	Swan neck 25°	0368 155 890	x	Excluding wear parts
-	Swan neck 25°, extended 100 mm	0368 155 892		Excluding wear parts
400	Swan neck, straight	0368 155 894		Excluding wear parts
-	Swan neck, straight, extended 100 mm	0368 155 896		Excluding wear parts
401	Gas nozzle, standard	0459 073 882	x	D/d 20/16 mm
401a	Gas nozzle, conical	0458 465 882	(A)	D/d 17/13 mm, incl item 403b
401b	Gas nozzle, straight	0458 470 882	(A)	D/d 18/13 mm
402	Contact tip	-		See Wear parts on page 29
403	Spatter protection	0366 396 003	x	Included in item 401
403b	Spatter protection	0458 471 003	x	Included in item 401a and 401b
404	Tip adapter M6	0368 145 001	x	M6
-	Tip adapter Helix M7	0368 683 001	x	HELIX, M7
405	Insulation bushing	0366 397 002	x	
406	Clamping sleeve	0459 770 001	x	
407	Support sleeve kit	0700 200 204	x	0700 200 170 valid before week 628
408	Cable assembly 1.5 m	0700 200 198	x	
408	Cable assembly 2.2 m	0700 200 202	x	
408	Cable assembly 3.0 m	0700 200 206	x	
409	Support sleeve	0700 200 150	x	
410	Adapter nut	0700 200 097	x	
411	Central connector	0700 200 151	x	Including control leads
412	Liner	-	-	See Wire liner on page 31-32

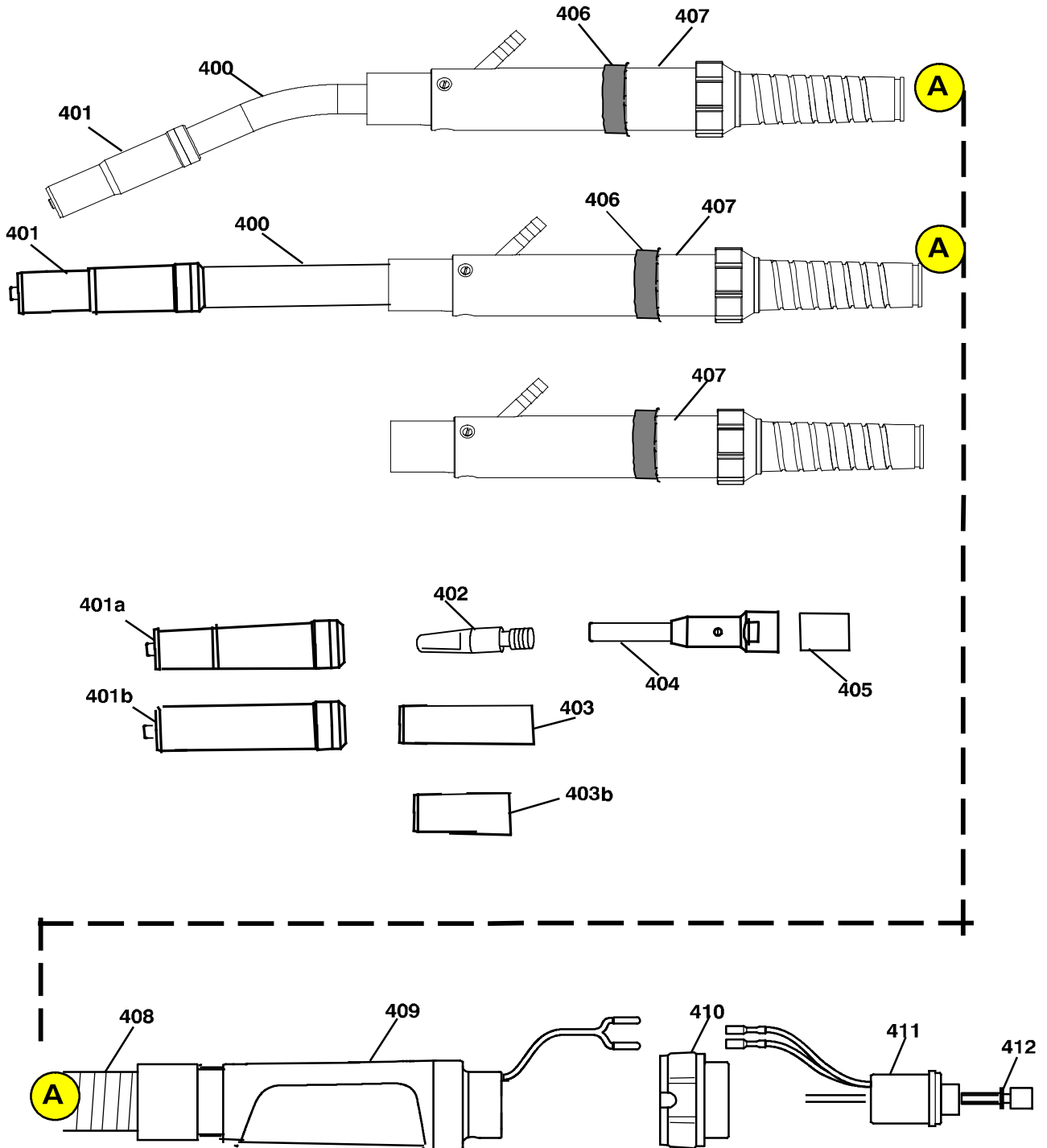

PSF 250C, PSF 315C LD

(x) = standard delivery (W) = wear part (A) = accessory

Pos	Denomination	Ordering no.	PSF 250C	PSF 315C LD	Notes
	Welding torch 3.0 m	0468 410-	-882	-885	EURO Connection
	Welding torch 4.5 m	0468 410-	-883	-886	EURO Connection
500	Swan neck std	0366 315 880	x		
500	Swan neck std	0457 862 880		x	
501	Gas nozzle standard	0458 464 881	x		
501	Gas nozzle standard	0458 464 882		x	
502a	Gas nozzle straight	0458 470 881	(A)		
502a	Gas nozzle straight	0458 470 882		(A)	
502b	Gas nozzle conical	0458 465 881	(A)		
502b	Gas nozzle conical	0458 465 882		(A)	
503	Spatter protection	0458 471 002	x		
503	Spatter protection	0458 471 003		x	
504	Contact tip				see Wear parts on page 28
505a	Tip adapter M6	0366 314 001	x		
505a	Tip adapter M6	0366 394 001		x	
505a	Tip adapter M8	0460 819 001		(A)	
505b	Tip adapter Helix M7	0368 310 001	(A)		
505b	Tip adapter Helix M7	0368 311 001		(A)	
506	Insulation bushing	0366 397 001	x		
506	Insulation bushing	0366 397 002		x	
507	Nut		x	x	M10x1
508	Mounting sleeve	0455 904 001	x	x	
509	Valve	0369 791 001	x	x	
510a	Suction nozzle L=40	0369 796 002	(A)	x	Conical out
510b	Suction nozzle L=54	0466 905 003	(A)		Conical in
510b	Suction nozzle L=75	0466 905 002	x		Conical in
510b	Suction nozzle L=54	0466 905 004		(A)	Conical in
511a	Trigger	0365 840 880	x	x	
511b	Micro switch	0341 934 880	x	x	
512	Handle complete	0466 977 880	x		Screws included
512	Handle complete	0457 861 880		x	Screws included
513	Swivel	0700 200 199	x	x	
514	Damask complete	0459 768 880	(A)	(A)	
515	Exhaust hose Ø28	0700 200 168	x	x	
516	Manifold kit Ø28	0700 200 166	x	x	
517	Support sleeve	0700 200 152	x	x	
518	Adapter nut	0700 200 097	x	x	
519	Central connector	0700 200 151	x	x	

PSF 250C, PSF 315C LD

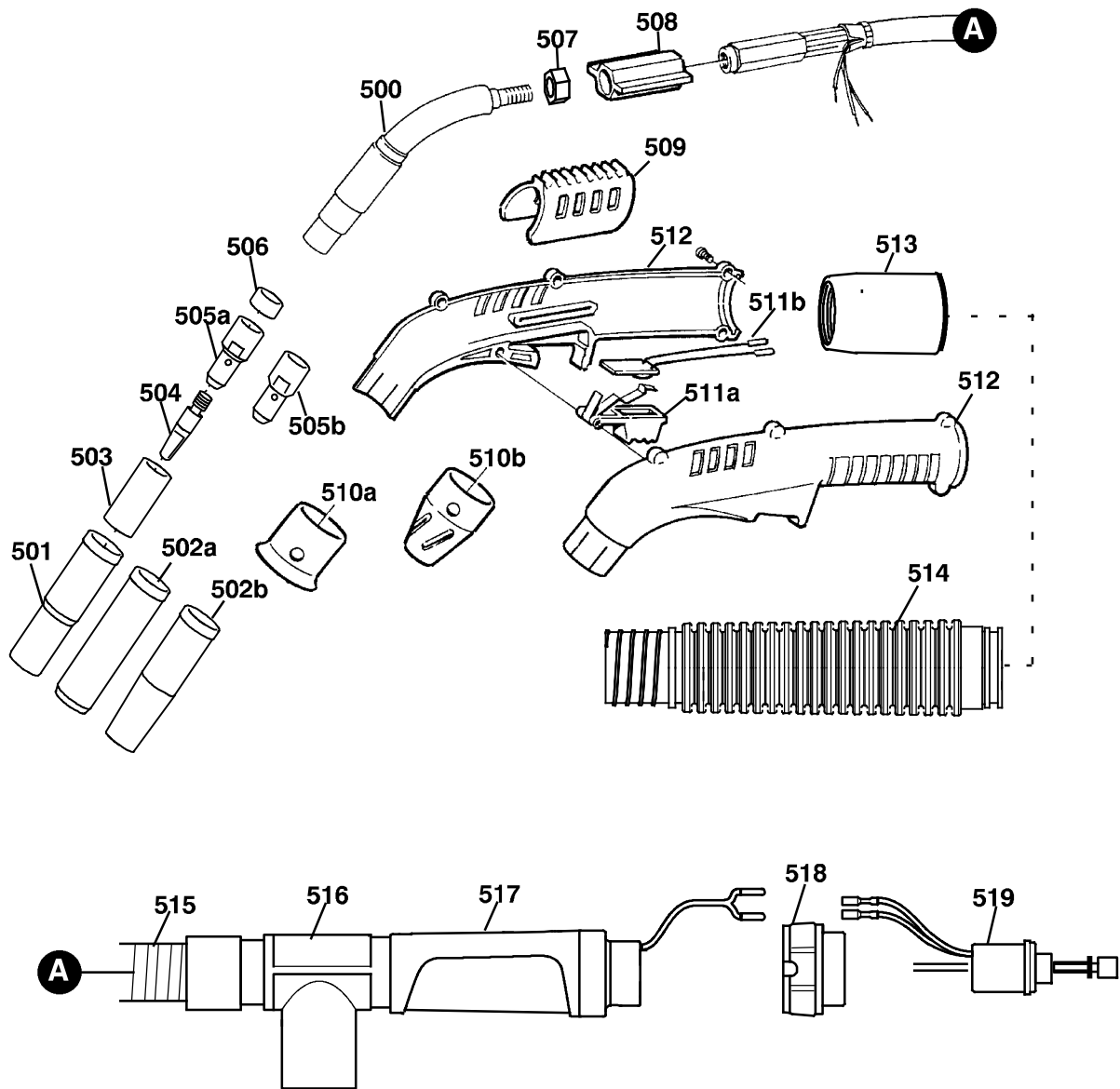

PSF 405C, PSF 405C RS3

(x) = standard delivery (W) = wear part (A) = accessory

Pos	Denomination	Ordering no.	PSF 405C	PSF 405C RS3	Notes
	Welding torch 3.0 m	0458 499-	-882		EURO Connection
	Welding torch 4.5 m	0468 499-	-883	-889	EURO Connection
600	Swan neck standard	0459 763 880	x	x	
601	Gas nozzle standard	0458 464 883	x	x	
602a	Gas nozzle straight	0458 470 883	(A)	(A)	
602b	Gas nozzle conical	0458 465 883	(A)	(A)	
603	Spatter protection	0458 471 004	x	x	
604	Contact tip	-			See Wear parts on page 28
605a	Tip adapter M8	0460 819 001	x	x	
605b	Tip adapter Helix M7	0368 311 001	(A)	(A)	
606	Insulation bushing	0366 397 002	x	x	
607	Mounting sleeve	0458 761 001	x	x	
608	Counter nut	0366 402 001	x	x	
609	Connection tube	0458 764 001	x	x	
610a	Suction nozzle	0458 495 001	x	x	Conical out
610b	Suction nozzle	0458 498 001	(A)	(A)	Conical in
611	Sleeve	0458 494 001	x	x	
612	Handle complete	0458 809 880	x	x	Screws included
613	Valve	0369 791 001	x	x	
614	Blind cover	-	x	x	Included in 612
615	Remote switch, compl	0458 420 880	x	x	Included in RS3 models only
616	Trigger	0458 810 880	x	x	
617	Mechanical switch	0369 611 880	x	x	
618	Swivel incl locking nut	0700 200 200	x	x	
619	Exhaust hose Ø32	0700 200 167	x	x	
620	Manifold kit Ø32	0700 200 169	x	x	
621	Pin plug, 23-pole	0368 541 005		x	Included in RS3 models onl
622	Support sleeve	0700 200 152	x	x	
623	Adapter nut	0700 200 097	x	x	
624	Central connector	0700 200 151	x	x	
625	Connector pin	0323 945 004		x	50 pcs

PSF 405C, PSF 405C RS3

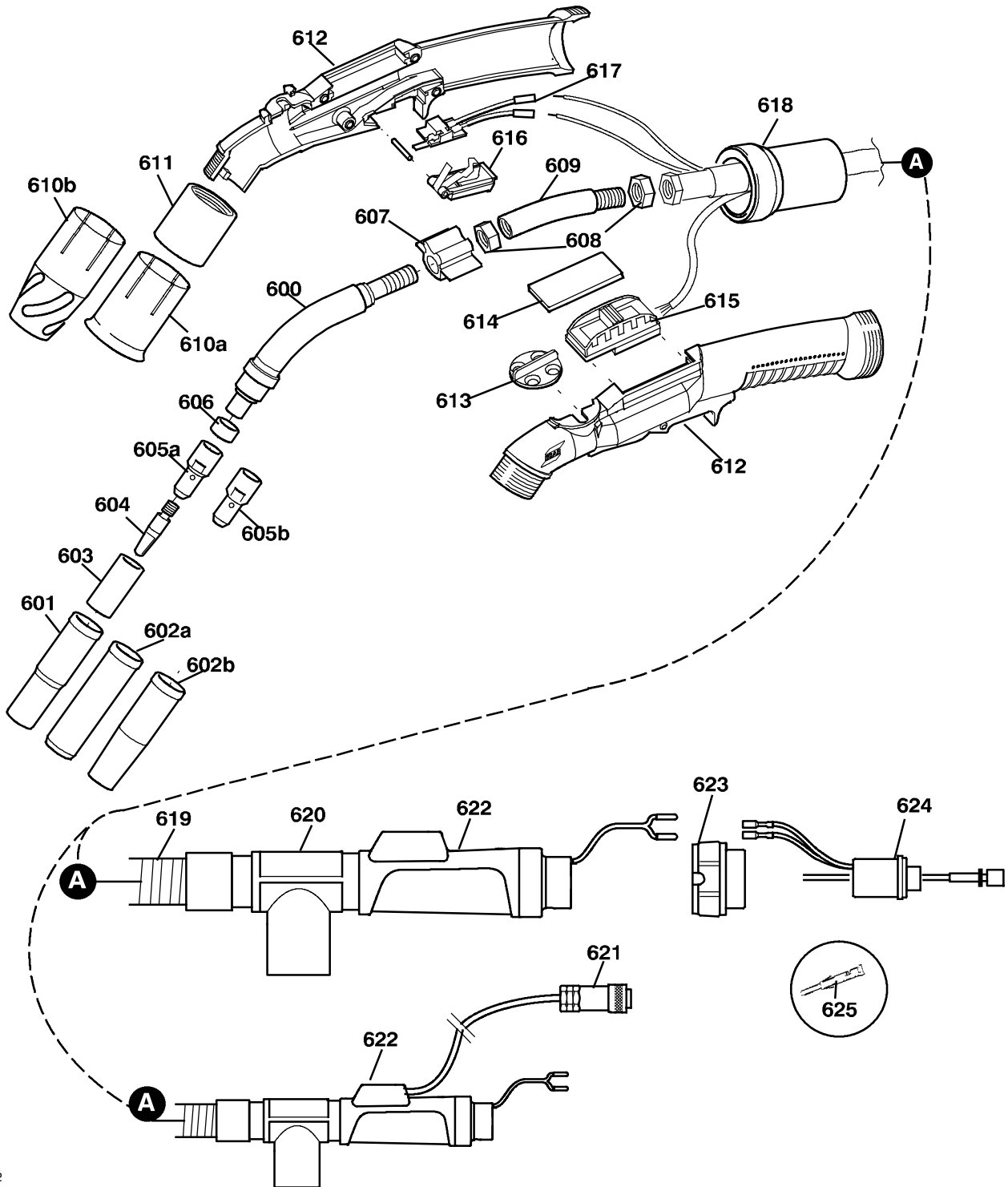

AH0713

PSF 410Cw, PSF 410Cw RS3

(x) = standard delivery (W) = wear part (A) = accessory

Pos	Denomination	Ordering no.	PSF 410CW	PSF 410CW RS3	Notes
	Welding torch 3.0 m	0458 450-	-880	-884	EURO Connection
	Welding torch 4.5 m	0458 450-	-881	-885	EURO Connection
700	Swan neck complete	0458 487 880	x	x	Includes 701, 703, 705a
701	Gas nozzle standard Ø16	0458 464 882	x	x	
702a	Gas nozzle straight Ø18	0458 470 882	x	x	
702b	Gas nozzle conical Ø13	0458 465 882	x	x	
702c	Gas nozzle "Slip on"	0469 754 880	(A)	(A)	
702d	Cooling sleeve "Slip on"	0469 758 880	(A)	(A)	
703	Spatter protection	0458 471 003	x	x	
703b	Spatter protection "Slip on"	0469 540 001	(A)	(A)	
704	Contact tip see table 1-3				
705a	Tip adapter M6	0366 394 001	(A)	(A)	
705a	Tip adapter M8	0460 819 001	x	x	
705b	Tip adapter Helix M7	0368 311 001	(A)	(A)	
706	Suction nozzle	0458 495 001	x	x	Conical out
707	Suction nozzle	0458 498 001	(A)	(A)	Conical in
708	Sleeve	0458 494 001	x	x	
709	Handle complete	0458 809 880	x	x	Include 710 and screws
710	Valve	-	x	x	Included in pos 709
711	Blind cover	-	x	x	Included in 709
712	Remote switch, complete	0458 420 880	x	x	Included RS3 models only
713	Trigger	0458 810 880	x	x	
714	Mechanical switch	0369 611 880	x	x	
715	Swivel complete	0700 200 200	x	x	
716	Exhaust hose Ø 32	0700 200 167	x	x	Ordering in length
717	Moss cup	0460 306 880	x	x	Complete set, 5 blue and 5 red
718	Manifold kit Ø 32	0700 200 169	x	x	
719	Pin plug, 23-pole	0368 541 005		x	Included RS3 models only
720	Hose supply, blue	0456 496 002	x	x	Ordering length in metre
721	Hose connection kit	0459 673 880	x	x	Quick connector clamp
722	Hose return red	0466 558 882	x	x	3 m
722	Hose return red	0466 558 883	x	x	4.5 m
723	Support hose	0458 490 880	x	x	3 m
723	Support hose	0458 490 881	x	x	4.5 m
724	Support sleeve	0700 200 152	x	x	Complete incl screw
725	Current / water cable	0700 200 162	x	x	3 m
725	Current / water cable	0700 200 163	x	x	4.5 m
726	Adapter nut	0700 200 097	x	x	
727	Central connector	0700 200 153	x	x	
	Connector pin	0323 945 004	x	x	Solid pin requested 50 pcs

PSF 410Cw, PSF 410Cw RS3

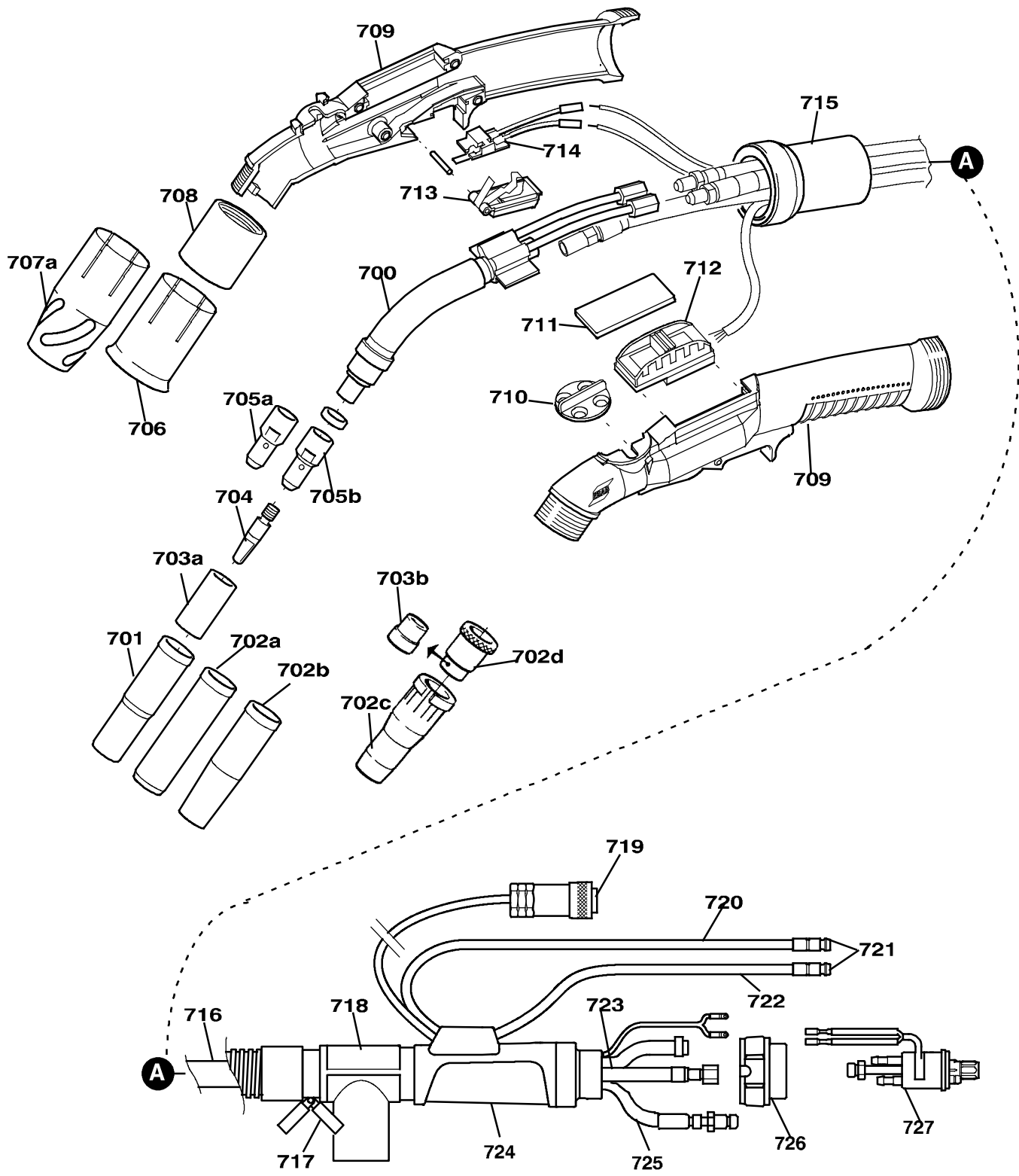

AH 0712

MXH 300 PP

(x) = standard delivery (W) = wear part (A) = accessory

Pos	Denomination	Ordering no.	MXH 300 PP	Notes
800a	Swan neck, straight	0700 200 252	x	
800b	Swan neck, 45°	0700 200 253	(A)	
801	Gas nozzle standard Ø16	0458 464 882	x	
801a	Gas nozzle conical Ø 14	0458 465 882	(A)	
801b	Gas nozzle straight Ø19	0458 470 882	(A)	
801c	Gas nozzle "Slip on"	0469 754 880	(A)	
801d	Cooling sleeve "Slip on"	0469758 880	(A)	
802a	Spatter protection	0458 471 003	x	
802b	Spatter protection "Slip on"	0469 540 001	(A)	
803	Contact tip			See Wear parts on page 30
804	Tip adapter M8 short	0460 819 001	(A)	
804	Tip adapter M8 long	0458 224 001	(A)	
805	Insulation washer	0458 874 001	x	
806a	Wear insert	0700 200 182	x	Cu tube complete suits 0.8 - 1.2 mm
806b	Wear insert	0700 200 183	(A)(W)	Brass spiral compl. 45° suits 0.8 - 1.2 mm
807	Torch body complete	0700 200 201	x	Incl pos 809 and 810
808	Drive roll cap complete	0700 200 188	x	Including 808a and 808b
808a	Ball	0700 200 190	x	10 pcs (Part of 808)
808b	Spring	0700 200 189	x	10 pcs (Part of 808)
809	Idler arm complete	0700 200 192	x	Including pos 810
810	Pressure roll	0700 200 193	x	
811	Feed roll 0.8 mm	0700 200 184	(A)	
811	Feed roll 1.0 mm	0700 200 185	(A)	
811	Feed roll 1.2 mm	0700 200 186	x	
812	Trigger complete	0700 200 196	x	
813	Handle complete	0700 200 195	x	Including screws
814	Motor complete	0700 200 187	x	24 V
814b	Potentiometer	0700 200 197	x	For adjustment of the wire feed speed, excl. the knob.
815	Brushes for gear motor	0700 200 194	x	2 pcs
816	Support sleeve	0700 200 152	x	Complete kit incl screw
817	Pin-plug, 23-pole	0368 541 005	x	
818	Adapter nut	0700 200 097	x	
819	Central connector	0700 200 207	x	Including control leads
820	Connector pin	0323 945 004	x	50 pcs
-	Steel liner	0700 200 176	(A)(W)	0.8 mm
-	Steel liner	0700 200 177	(A)(W)	1.0/1.2 mm
-	PTFE liner	0700 200 179	(A)(W)	0.8 mm
-	Polyamid-liner	0700 200 181	x	PA-liner, suits 1.0 - 1.2 mm

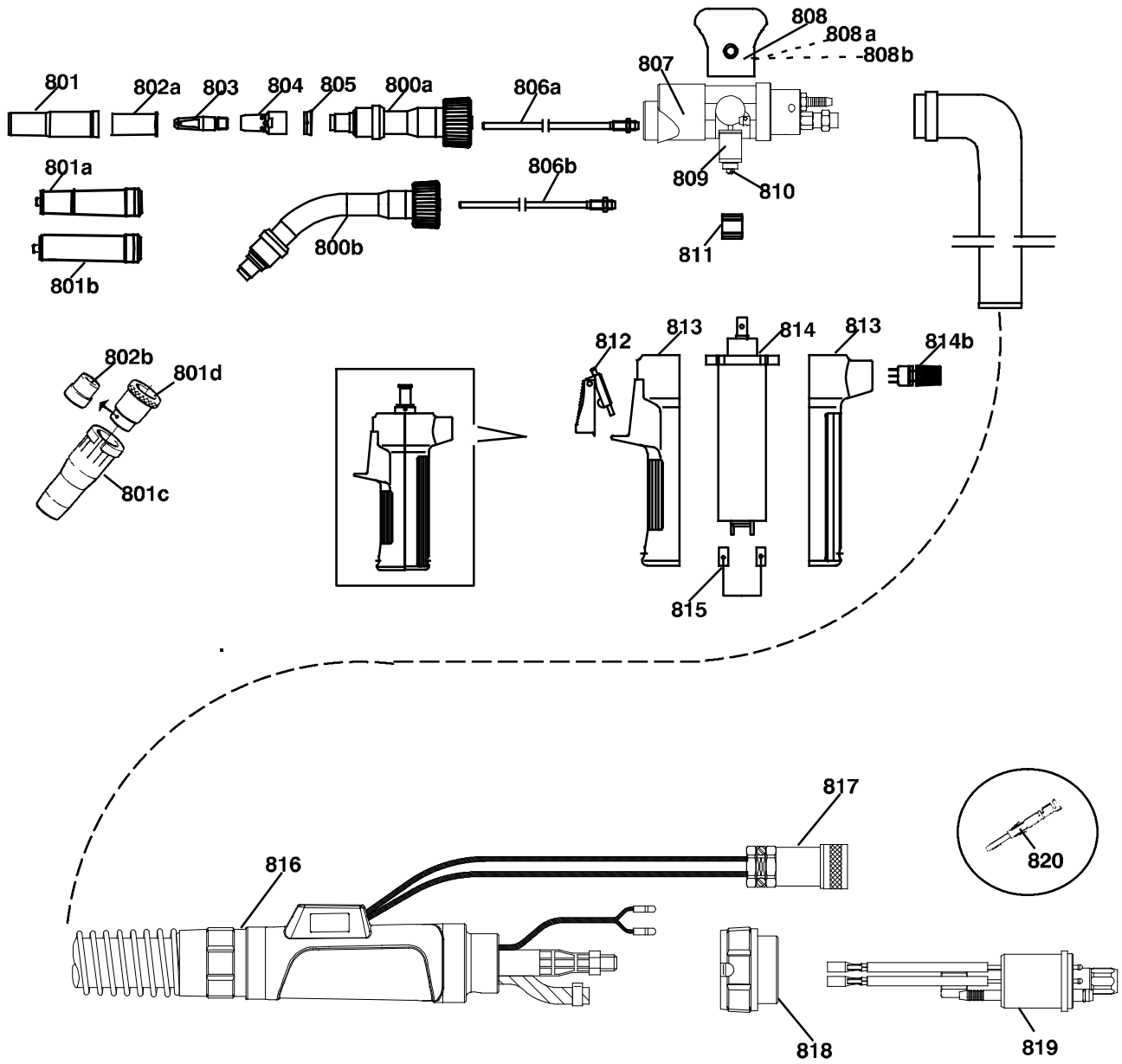

MXH 400w PP

(x) = standard delivery (W) = wear part (A) = accessory

Pos	Denomination	Ordering no.	MXH 400w PP	Notes
900a	Swan neck, straight	0700 200 250	x	
900b	Swan neck, 45°	0700 200 251	(A)	
901	Gas nozzle standard -16	0458 464 882	x	
901a	Gas nozzle conical -14	0458 465 882	(A)	
901b	Gas nozzle straight -19	0458 470 882	(A)	
901c	Gas nozzle "Slip on"	0469 754 880	(A)	
901d	Cooling sleeve "Slip on"	0469758 880	(A)	
902a	Spatter protection	0458 471 003	x	
902b	Spatter protection "Slip on"	0469 540 001	(A)	
903	Contact tip			See Wear parts on page 30.
904	Tip adapter M8 short	0460 819 001	(A)	
904	Tip adapter M8 long	0458 224 001	(A)	
905	Insulation washer	0458 874 001	x	
906a	Wear insert	0700 200 182	x	Cu tube compl. suits 0.8 - 1.6 mm
906b	Wear insert	0700 200 183	(A)(W)	Brass spiral compl. 45° suits 0.8 - 1.6 mm
907	Torch body complete	0700 200 191	x	Incl pos 909 and 910
908	Drive roll cap complete	0700 200 188	x	Including 808a and 908b
908a	Ball	0700 200 190	x	10 pcs (Part of 908)
908b	Spring	0700 200 189	x	10 pcs (Part of 908)
909	Idler arm complete	0700 200 192	x	Including pos 910
910	Pressure roll	0700 200 193	x	
911	Feed roll 0.8 mm	0700 200 184	(A)	
911	Feed roll 1.0 mm	0700 200 185	x	
911	Feed roll 1.2 mm	0700 200 186	(A)	
911	Feed roll 1.6 mm	0700 200 205	(A)	
912	Trigger complete	0700 200 196	x	
913	Handle complete	0700 200 195	x	Including screws
914	Motor complete	0700 200 187	x	24 V
914b	Potentiometer	0700 200 197	x	For adjustment of the wire feed speed, excluding the knob.
915	Brushes for gear motor	0700 200 194	x	2 pcs
916	Support sleeve	0700 200 152	x	Complete kit incl screw
917	Pin-plug, 23-pole	0368 541 005	x	
918	Hose supply, blue	0456 496 002	x	Order length in m
919	Hose connection kit	0459 673 880	x	Quick connector/clamp 10 pcs
920	Hose return, red	0456 496 001	x	Order length in m
921	Moss cap	0460 306 880	x	Complete set, 5 blue and 5 red
922	Current/water cable	0700 200 172	x	6.0 m
922	Current/water cable	0700 200 173	x	10.0 m
923	Support hose	0700 200 174	x	6.0 m
923	Support hose	0700 200 175	x	10.0 m
924	Adapter nut	0700 200 097	x	
925	Central connector	0700 200 171	x	Including control leads
926	Connector pin	0323 945 004	x	50 pcs
927	O-ring kit torch body	0700 200 203	x	5x of each size

MXH 400w PP

Pos	Denomination	Ordering no.	MXH 400w PP	Notes
-	Steel liner	0700 200 176	(A)(W)	0.8 mm
-	Steel liner	0700 200 177	(A)(W)	1.0 - 1.2 mm
-	PTFE liner	0700 200 179	(A)(W)	0.8 mm
-	Polyamid-liner	0700 200 181	x	PA-liner - Suits 1.0 - 1.6 mm

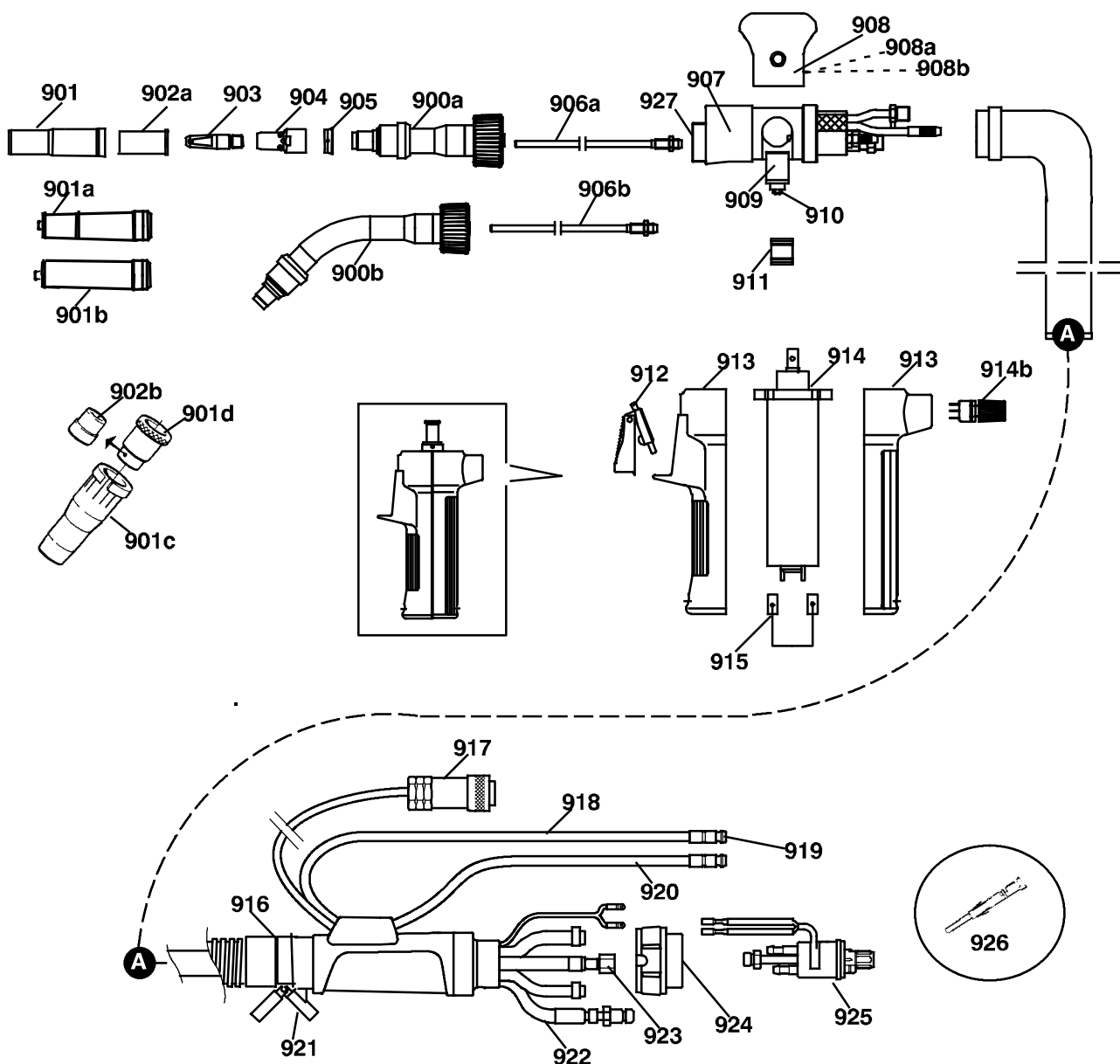

Wear components

Contact tips

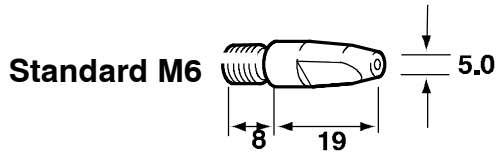

Shielding gas / Welding wire Ø		Contact tip M 6	
CO ₂	Mix / Ar		
0.6	-	0468 500 001	W0.6 0.8
-	0.6	0468 500 002	W0.8 0.9
0.8	-	0468 500 003	W0.8 1.0
0.9	0.8	0468 500 004	W0.9 1.1
1.0	0.9	0468 500 005	W1.0 1.2
-	1.0	0468 500 007	W1.2 1.5

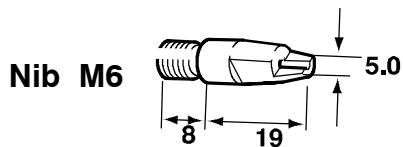

Shielding gas / Welding wire Ø		Contact tip M 6	
CO ₂	Mix / Ar		
-	0.6	0468 501 002	W0.8 1.0
0.8	-	0468 501 003	W0.9 1.1
0.9	0.8	0468 501 004	W1.0 1.2
1.0	0.9	0468 501 005	W1.2 1.5

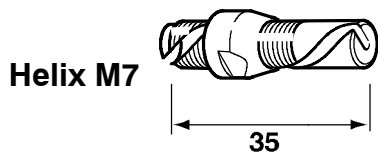

Shielding gas / Welding wire Ø		Contact tip M 7	
CO ₂	Mix / Ar		
-	0.6	0368 313 881	W0.8
0.9	0.8	0368 313 883	W1.0
1.0	0.9	0368 313 884	W1.2

Contact tips

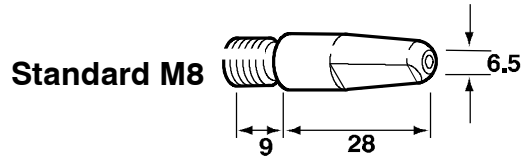
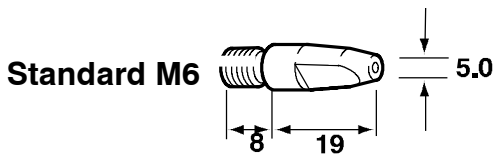

Gas / wire Ø		PSF 305		PSF 405 PSF 410w		PSF 505 PSF 510w		
CO ₂	Mix / Ar	M 6	M 8	M 6	M 8	M 8	M 6	M 8
0.6	-	0468 500 001	-	0468 500 001	-	-	W0.6 0.8	-
-	0.6	0468 500 002	-	0468 500 002	-	-	W0.8 0.9	-
0.8	-	0468 500 003	0468 502 003	0468 500 003	0468 502 003	0468 502 003	W0.8 1.0	W0.8 1.0
0.9	0.8	0468 500 004	0468 502 004	0468 500 004	0468 502 004	0468 502 004	W0.9 1.1	W1.0 1.1
1.0	0.9	0468 500 005	0468 502 005	0468 500 005	0468 502 005	0468 502 005	W1.0 1.2	W1.0 1.2
1.2	-	0468 500 006	0468 502 006	0468 500 006	0468 502 006	0468 502 006	W1.2 1.4	W1.2 1.4
1.2	1.0	0468 500 007	0468 502 007	0468 500 007	0468 502 007	0468 502 007	W1.2 1.5	W1.2 1.5
1.4	1.2	0468 500 008	0468 502 008	0468 500 008	0468 502 008	0468 502 008	W1.4 1.7	W1.4 1.7
1.6	-	-	-	0468 500 009	0468 502 009	0468 502 009	W1.6 1.9	W1.6 1.9
-	1.6	-	-	0468 500 010	0468 502 010	0468 502 010	W1.6 2.1	W1.6 2.1
2.0	2.0	-	-	-	-	0468 502 011	-	W2.0 2.4
2.4	2.4	-	-	-	-	0468 502 012	-	W2.4 2.8

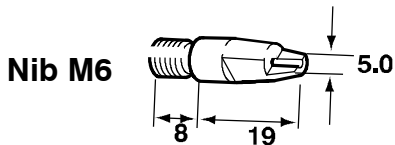

Shielding gas / Welding wire Ø		Contact nozzle		
CO ₂	Mix / Ar	M 6		
-	0.6	0468 501 002	W0.8	1.0
0.8	-	0468 501 003	W0.9	1.1
0.9	0.8	0468 501 004	W1.0	1.2
1.0	0.9	0468 501 005	W1.2	1.5
1.2	-	0468 501 006	W1.4	1.7

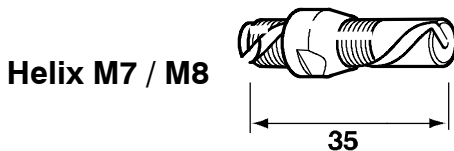

Shielding gas / Welding wire Ø		Contact nozzle			
CO ₂	Mix / Ar	M 7	M 8		
-	0.6	0368 313 881	-	W0.8	
0.9	0.8	0368 313 883	0368 313 983	W1.0	
1.0	0.9	0368 313 884	0368 313 984	W1.2	
1.2	-	0368 313 885	-	W1.4	

Contact tips

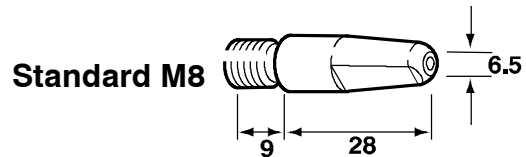
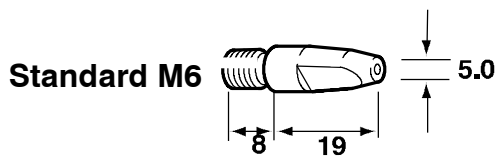

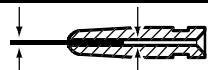
Gas / wire Ø		PSF 250C	PSF 315 CLD	PSF 405C		PSF 410Cw			
CO ₂	Mix / Ar	M 6	M 6	M 6	M 8	M 6	M 8	M 6	M 8
0.6	-	0468 500 001	0468 500 001	0468 500 001	-	0468 500 001	-	W0.6 0.8	-
-	0.6	0468 500 002	0468 500 002	0468 500 002	-	0468 500 002	-	W0.8 0.9	-
0.8	-	0468 500 003	0468 500 003	0468 500 003	0468 502 003	0468 500 003	0468 502 003	W0.8 1.0	W0.8 1.0
0.9	0.8	0468 500 004	0468 500 004	0468 500 004	0468 502 004	0468 500 004	0468 502 004	W0.9 1.1	W1.0 1.1
1.0	0.9	0468 500 005	0468 500 005	0468 500 005	0468 502 005	0468 500 005	0468 502 005	W1.0 1.2	W1.0 1.2
1.2	-	0468 500 006	0468 500 006	0468 500 006	0468 502 006	0468 500 006	0468 502 006	W1.2 1.4	W1.2 1.4
1.2	1.0	0468 500 007	0468 500 007	0468 500 007	0468 502 007	0468 500 007	0468 502 007	W1.2 1.5	W1.2 1.5
1.4	1.2	-	0468 500 008	0468 500 008	0468 502 008	0468 500 008	0468 502 008	W1.4 1.7	W1.4 1.7
1.6	-	-	-	0468 500 009	0468 502 009	0468 500 009	0468 502 009	W1.6 1.9	W1.6 1.9
-	1.6	-	-	0468 500 010	0468 502 010	0468 500 010	0468 502 010	W1.6 2.1	W1.6 2.1

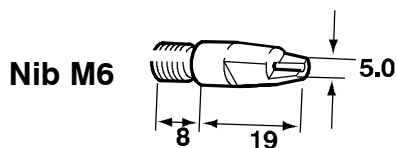

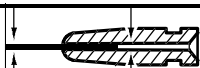
Shielding gas / Welding wire Ø		Contact nozzle		
CO ₂	Mix / Ar	M 6		
-	0.6	0468 501 002	W0.8	1.0
0.8	-	0468 501 003	W0.9	1.1
0.9	0.8	0468 501 004	W1.0	1.2
1.0	0.9	0468 501 005	W1.2	1.5
1.2	-	0468 501 006	W1.4	1.7

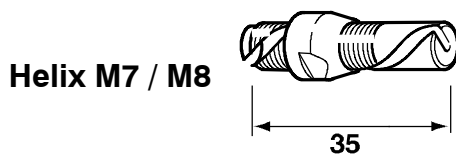

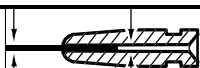
Shielding gas / Welding wire Ø		Contact nozzle			
CO ₂	Mix / Ar	M 7	M 8		
-	0.6	0368 313 880	-	W0.8	
0.9	0.8	0368 313 883	0368 313 983	W1.0	
1.0	0.9	0368 313 884	0368 313 984	W1.2	
1.2	-	0368 313 885	-	W1.4	

Contact tips

Standard M6 **ESAB**

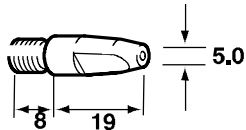

Standard M6 **ABB**

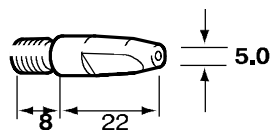

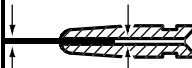
Welding wire		Contact-tip hole Ø	Ordering No M6 x 27 ESAB	Marked 	Wire Ø	Ordering No M6 x 30 ABB	Contact tip hole Ø
Short arc CO ₂	Spray arc MIX						
(0.8)	0.6	0.9	0468 500 002	W0.8 ESAB	0.8	0153 500 202	1.0
0.8	(0.8)	1.0	0468 500 003	W0.8 ESAB	0.9	0153 500 203	1.1
0.9	0.8	1.1	0468 500 004	W0.9 ESAB	1.0	0153 500 204*	1.2
1.0	0.9	1.2	0468 500 005	W1.0 ESAB	-	-	-
1.1	(1.0)	1.3	0468 500 006	W1.2 ESAB	-	-	-
1.2	1.0-1.1	1.5	0468 500 007	W1.2 ESAB	-	-	-

* Is delivered as standard

Helix M7

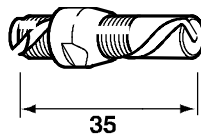

Helix M7 contact tip must be combined with special tip adapter. See spare parts list.

Ordering number M7 HELIX	Marked 
0368 313 881	W0.8 -
0368 313 883	W1.0 -
0368 313 884	W1.2 -

Contact tips

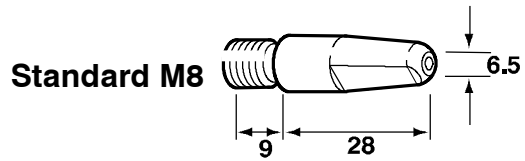

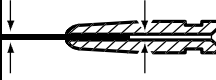
Welding wire		Contact tip hole Ø	Ordering No M8 x 37	Marked 
Short arc CO ₂	Spray arc MIX			
0.8	(0.8)	1.0	0468 502 003	W0.8 1.0
0.9	0.8	1.1	0468 502 004	W0.9 1.1
1.0	0.9	1.2	0468 502 005	W1.0 1.2
1.2	1.0-1.1	1.5	0468 502 007 *	W1.2 1.5

*) Is delivered as standard

Welding guns & torches

Wire liner

Welding torch	Welding wire	Steel spiral liner		PTFE ceramic liner*) (beige)	
		3 m	4.5 m	3 m	4.5 m
PSF 250, PSF 250C	0.6-0.8 mm	0366 549 882	0366 549 883	-	-
	0.9-1.0 mm	0366 549 884	0366 549 885	0457 969 882	0457 969 883
PSF 305, PSF 315 CLD	1.2 mm	0366 549 886	0366 549 887	0457 969 882	0457 969 883
PSF 405, PSF 405C, PSF 410w, PSF 410Cw	1.4 mm	0366 549 888	0366 549 889	0457 969 884	-
	1.6 mm	0366 549 890	0366 549 891	-	-
PSF 505, PSF 510w	2.0 mm	-	0366 549 898	-	-
The wire guide is marked with the max. wire diameter (stamped on the nipple). *) No wear insert needed.					

Welding torch	Welding wire	PTFE liner incl. wear insert (steel, white)		Wear insert separate for PTFE liner PTFE (Al)
		3 m	4.5 m	
PSF 250, PSF 250C	0.8 mm	0366 550 882	0366 550 883	0368 742 880
	0.9-1.0 mm	0366 550 884	0366 550 885	0368 742 880
PSF 305, PSF 315 CLD	1.2 mm	0366 550 886	0366 550 887	0368 742 883
PSF 405, PSF 405C, PSF 410w, PSF 410Cw	1.4 mm	0366 550 888	0366 550 889	0368 742 881
	1.6 mm	0366 550 890	0366 550 891	0368 742 881
PSF 505, PSF 510w	2.0/2.4 mm	0366 550 892	0366 550 893	-
The wire guide is marked with the max. wire diameter (stamped on the nipple).				

Welding guns & torches



Welding torch	Welding wire *)	PTFE conduit incl. wear insert (steel) 3 m	Wear insert separate PTFE (Al)
PSF 315 M/R	0.8 mm	0366 550 882	0368 742 880
	0.9-1.0 mm	0366 550 884	0368 742 880
	1.2 mm	0366 550 886	0368 742 881
*) The wire guide aperture = 1.5 x wire diameter. The wire guide is marked with the max. wire diameter (stamped on the nipple).			

Welding torch	Welding wire *)	Steel spiral 3 m	PTFE ceramic liner 3 m **)
PSF 315 M/R	0.6-0.8 mm	0366 549 882	-
	0.9-1.0 mm	0366 549 884	0457 969 882
	1.2 mm	0366 549 886	0457 969 882
*) The wire guide aperture = 1.5 x wire diameter. The wire guide is marked with the max. wire diameter (stamped on the nipple).			
**) To be cut to gun length.			

Welding torch	Welding wire *)	Steel liner 10 m	PTFE liner 10 m
MXH 300 PP/ MXH 400w PP	0.8 mm	0700 200 176	0700 200 179
	1.0 /1.2 mm	0700 200 177	-
MXH 400w PP	1.0 /1.6 mm	-	0700 200 181
*) The wire guide aperture = 1.5 x wire diameter. The wire guide is marked with the max. wire diameter (stamped on the nipple).			

Welding guns & torches

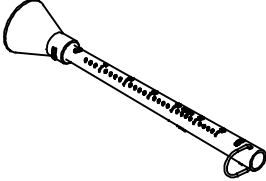
Accessories

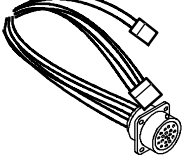
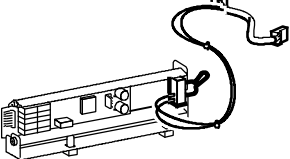
	<p>Gas flow meter 0155 716 880</p>
	<p>MIG handy support 0760 022 300 with strong magnetic fo</p>
	<p>MXH 300 PP / MXH 400w PP Connection kit for Feed 3004 / 4804, Feed L3004 0459 020 883</p>
	<p>MXH 300 PP / MXH 400w PP Connection and wire feed control kit Feed 3004/4804/L3004 0459 681 881 Mig C3000i 0459 681 891</p>
	<p>MXH 300 PP / MXH 400w PP Connection kit Mig C340 PRO, 0349 308 980</p>
	<p>MXH 300 PP / MXH 400w PP Connection kit Mig C420 PRO, 0349 308 337</p>
	<p>MXH 300 PP - Swan neck 45° 0700 200 253</p>
	<p>MXH 400w PP - Swan neck 45° 0700 200 251 water-cooled</p>
	<p>Spot welding accessory Self and water cooled PSF 250, PSF 250C 0366 643 881 PSF 305, PSF 410w, PSF 315 CLD, PSF 410Cw 0366 643 882 PSF 405, PSF 510w, PSF 405C 0366 643 883 PSF 505 0366 643 884</p>

ESAB subsidiaries and representative offices

Europe

AUSTRIA

ESAB Ges.m.b.H
Vienna-Liesing
Tel: +43 1 888 25 11
Fax: +43 1 888 25 11 85

BELGIUM

S.A. ESAB N.V.
Brussels
Tel: +32 2 745 11 00
Fax: +32 2 726 80 05

THE CZECH REPUBLIC

ESAB VAMBERK s.r.o.
Prague
Tel: +420 2 819 40 885
Fax: +420 2 819 40 120

DENMARK

Aktieselskabet ESAB
Copenhagen-Valby
Tel: +45 36 30 01 11
Fax: +45 36 30 40 03

FINLAND

ESAB Oy
Helsinki
Tel: +358 9 547 761
Fax: +358 9 547 77 71

FRANCE

ESAB France S.A.
Cergy Pontoise
Tel: +33 1 30 75 55 00
Fax: +33 1 30 75 55 24

GERMANY

ESAB GmbH
Solingen
Tel: +49 212 298 0
Fax: +49 212 298 204

GREAT BRITAIN

ESAB Group (UK) Ltd
Waltham Cross
Tel: +44 1992 76 85 15
Fax: +44 1992 71 58 03

ESAB Automation Ltd

Andover
Tel: +44 1264 33 22 33
Fax: +44 1264 33 20 74

HUNGARY

ESAB Kft
Budapest
Tel: +36 1 20 44 182
Fax: +36 1 20 44 186

ITALY

ESAB Saldatura S.p.A.
Mesero (Mi)
Tel: +39 02 97 96 81
Fax: +39 02 97 28 91 81

THE NETHERLANDS

ESAB Nederland B.V.
Utrecht
Tel: +31 30 248 59 22
Fax: +31 30 248 52 60

NORWAY

AS ESAB
Larvik
Tel: +47 33 12 10 00
Fax: +47 33 11 52 03

POLAND

ESAB Sp.z.o.o
Warszaw
Tel: +48 22 813 99 63
Fax: +48 22 813 98 81

PORTUGAL

ESAB Lda
Lisbon
Tel: +351 1 837 1527
Fax: +351 1 859 1277

SLOVAKIA

ESAB Slovakia s.r.o.
Bratislava
Tel: +421 7 44 88 24 26
Fax: +421 7 44 88 87 41

SPAIN

ESAB Ibérica S.A.
Alcobendas (Madrid)
Tel: +34 91 623 11 00
Fax: +34 91 661 51 83

SWEDEN

ESAB Sverige AB
Gothenburg
Tel: +46 31 50 95 00
Fax: +46 31 50 92 22

ESAB International AB

Gothenburg
Tel: +46 31 50 90 00
Fax: +46 31 50 93 60

SWITZERLAND

ESAB AG
Dietikon
Tel: +41 1 741 25 25
Fax: +41 1 740 30 55

North and South America

ARGENTINA

CONARCO
Buenos Aires
Tel: +54 11 4 753 4039
Fax: +54 11 4 753 6313

BRAZIL

ESAB S.A.
Contagem-MG
Tel: +55 31 3369 4333
Fax: +55 31 3369 4440

CANADA

ESAB Group Canada Inc.
Mississauga, Ontario
Tel: +1 905 670 02 20
Fax: +1 905 670 48 79

MEXICO

ESAB Mexico S.A.
Monterrey
Tel: +52 8 350 5959
Fax: +52 8 350 7554

USA

ESAB Welding & Cutting Products
Florence, SC
Tel: +1 843 669 44 11
Fax: +1 843 664 44 58

Asia/Pacific

CHINA

Shanghai ESAB A/P
Shanghai
Tel: +86 21 6539 7124
Fax: +86 21 6543 6622

INDIA

ESAB India Ltd
Calcutta
Tel: +91 33 478 45 17
Fax: +91 33 468 18 80

INDONESIA

P.T. Esabindo Pratama
Jakarta
Tel: +62 21 460 01 88
Fax: +62 21 461 29 29

MALAYSIA

ESAB (Malaysia) Snd Bhd
Selangor
Tel: +60 3 703 36 15
Fax: +60 3 703 35 52

SINGAPORE

ESAB Singapore Pte Ltd
Singapore
Tel: +65 861 43 22
Fax: +65 861 31 95

ESAB Asia/Pacific Pte Ltd

Singapore
Tel: +65 861 74 42
Fax: +65 863 08 39

SOUTH KOREA

ESAB SeAH Corporation
Kyung-Nam
Tel: +82 551 289 81 11
Fax: +82 551 289 88 63

UNITED ARAB EMIRATES

ESAB Middle East
Dubai
Tel: +971 4 338 88 29
Fax: +971 4 338 87 29

Representative offices

BULGARIA

ESAB Representative Office
Sofia
Tel/Fax: +359 2 974 42 88

EGYPT

ESAB Egypt
Dokki-Cairo
Tel: +20 2 390 96 69
Fax: +20 2 393 32 13

ROMANIA

ESAB Representative Office
Bucharest
Tel/Fax: +40 1 322 36 74

RUSSIA-CIS

ESAB Representative Office
Moscow
Tel: +7 095 937 98 20
Fax: +7 095 937 95 80

ESAB Representative Office

St Petersburg
Tel: +7 812 325 43 62
Fax: +7 812 325 66 85

Distributors

For addresses and phone numbers to our distributors in other countries, please visit our home page

www.esab.com



ESAB AB
SE-695 81 LAXÅ
SWEDEN
Phone +46 584 81 000

www.esab.com

